

MAGNET UNIT / GRUPO MAGNETICO

HOLD IN / ENGANCHE ≤180mA
 DROP OUT / DESSENGANCHE ≥60mA

DESCRIPTION DESCRIPCION	OPTIONS OPCIONES			
A	S/CUSTOMER / S/CLIENTE mm			
B	S/CUSTOMER / S/CLIENTE mm			
C	25	30	37	
D	M8	M9	M10	11/32"
BY-PASS	REGULABLE		FIXED / FIJO	
PILOT / PILOTO	YES / SI		NO	
SPINDLE / POSICION POSITION / PERNO	0° ○	90° ⊙	180° ⊖	240° ⊙

Bezeroa: Bezero Erref.: Material:
 Cliente: Ref. Cliente: Material:

CPMM 18700/BRIDA GENERICO

Ber. / Data Rev. / Fecha	Zk. / Nº	Egilea / Autor	Aldaketa / Modificación

Eskala:
 Escala:
 Marraztua:
 Dibujado:
 Data:
 Fecha:
 Onartua:
 Comprobado:
 Data:
 Fecha:

Plano Zenbakia:
 N° de Plano:
A3 98089130

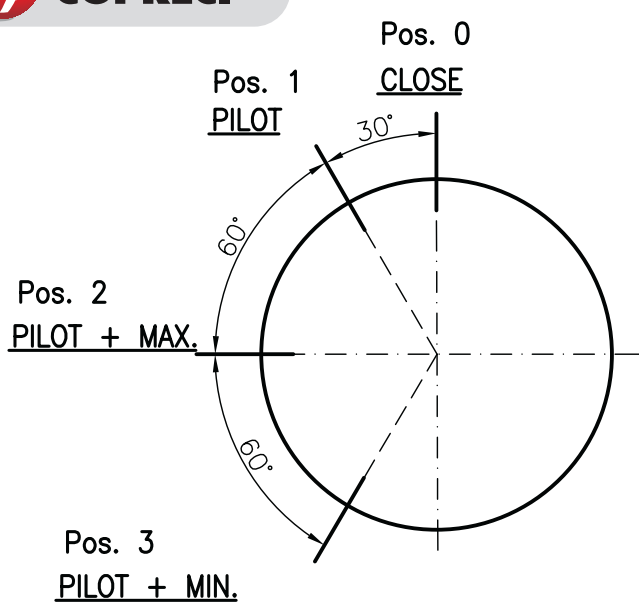

A- GENERAL DIAGRAM

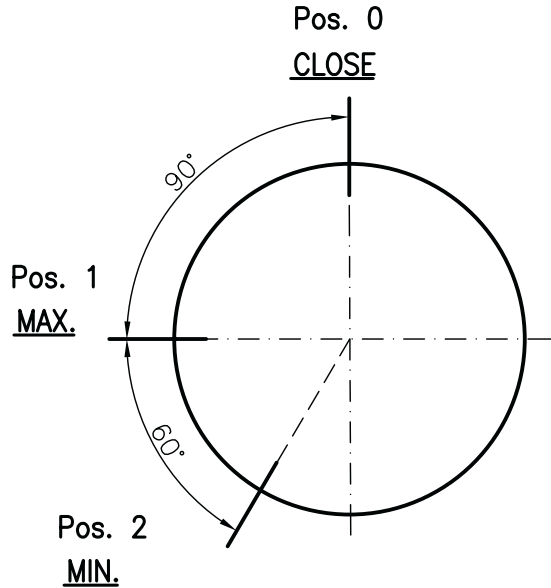

B- WITHOUT PILOT OUTLET

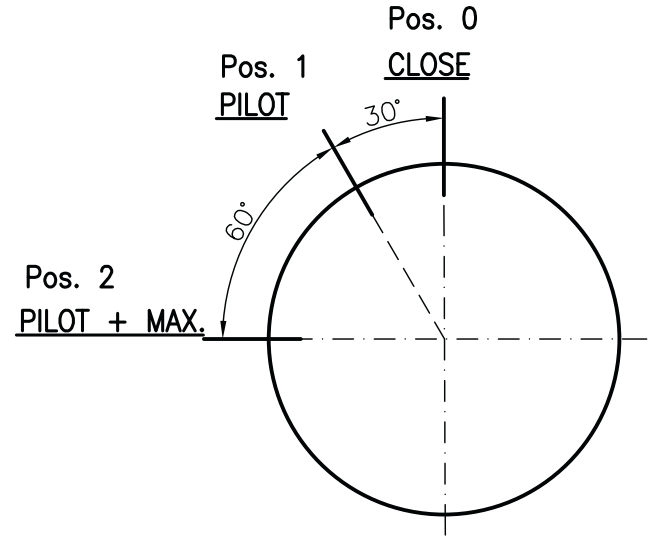

C- ONLY PILOT AND MAXI FLOW

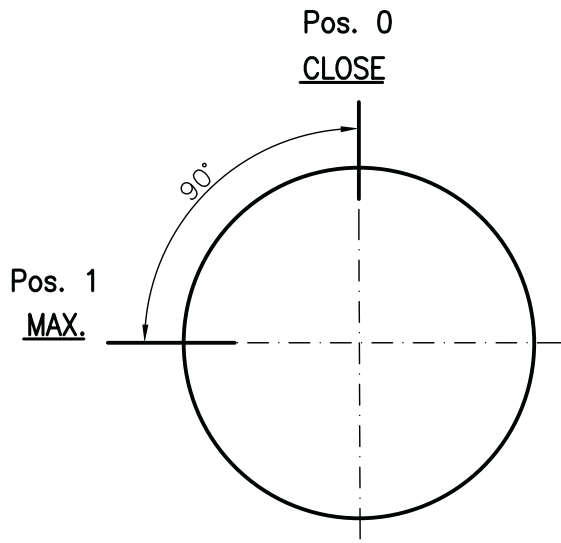

D- ONLY MAXI FLOW

TURN DIAGRAM OPTIONS